

# COMROD AT100D

## 10 m Marine Transmitting Antenna

### Application:

AT100D is a high quality glassfibre transmitting antenna for marine coastal and HF telephony bands. It matches well all modern SSB marine telephony transmitters.

### Electrical specifications:

Frequency range	1.6-30 MHz
Power rating	1.5 kW PEP
Impedance	See diagram on reverse side
Pattern	Omnidirectional
Polarization	Vertical
Electrical length	10 m (33 ft)

### Mechanical specifications:

Design	Selfsupporting fiberglass rod with bronze armature and epoxy insulated feeding point
Height	10 m (33 ft)
Weight	18.9 kg
Sections	Base section: ATB50 16.3 kg Top section: APB50 2.6 kg
Wind rating	55 m/s = 125 mph
Moment of flexure	275 kpm at 55 m/s
Deflection due to wind load	5 m (16.7 ft) at tip ball at 55 m/s wind load
Finish	Polyurethane lacquer, white
Temperature range	-55 °C, +55 °C; -67 °F, +131 °F
Optional	Side feed, see data sheet no. 06-6-006

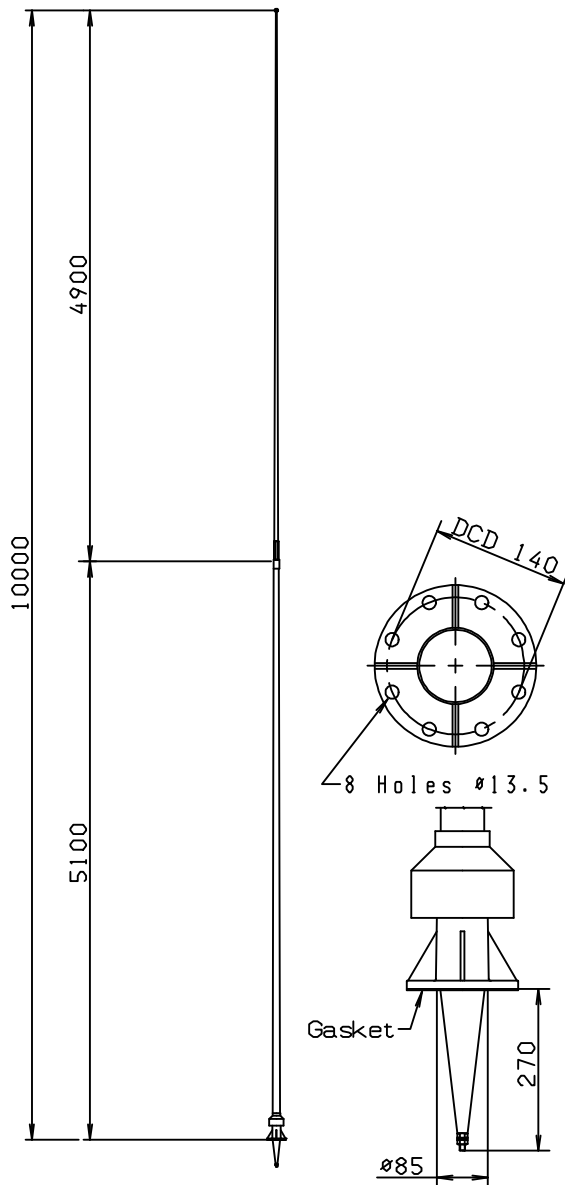

### Mounting:

The AT100D is well suited for mounting on top of the radio cabin. If the feeding insulator is not long enough, extensions are available.

The flange holes are matched to M12 bolts.

Frequency (MHz)	Impedance AT100D
1.6	5-j1000
2.0	6-j600
3.0	10-j350
4.0	11-j200
6.0	24-j34
7.0	48+j57
8.0	80+j140
9.0	180+j275
11.0	750+j60
12.0	500-j350
13.0	250-j360
14.0	150-j300
16.0	70-j180
17.0	55-j135
22.0	200+j130
23.0	350+j60
25.0	275-j200
30.0	68-j52.5